

The background of the advertisement is a dark, high-contrast photograph of a motorcycle's engine and chassis. The lighting is dramatic, highlighting the metallic textures and complex mechanical parts. In the lower-left foreground, a silver, cylindrical IXIL exhaust pipe is prominently displayed, angled towards the center. The pipe has a textured, woven appearance and the IXIL logo is visible on its side. The overall aesthetic is sleek and technical.

IXIL
exhaust

Make **it** perfect

2026

IXIL
exhaust



6	COMPANY PROFILE
8	RACING
12	TUNING

16 **IXIL EXHAUST**

18	RB
20	RC
22	RC3B
24	XC
26	SX1
28	MXT
30	MXR
32	RALLY
34	L5X
36	L3XB
38	L2X
40	SOVE
42	V4S
44	V4B
46	VTR

48 **IRONHEAD**

50	HC2
52	HC2B
54	HC1
56	HC1B
58	OVC11
60	OVC13

62 **APPLICATION LIST**

IXIL came onto the market in 1955, backed by a family business in the heart of Barcelona.

The constant efforts and determination of two generations to offer products with the best possible guarantees have been fundamental in obtaining world-wide recognition. Splendid teamwork in the manufacture, commercialization and distribution of the brand make us competitive in the international market.

The latest technology is used in all our production processes so that we can meet the highest European standards. Our product development is based on computer-assisted design (CAD), giving greater speed and high precision in adaptations.

The whole production process is computer supported, from the laser cutting machines to the welding robots.

IXIL takes part in the racing world and enjoys the confidence of world class competitors in the top Moto GP category.

where new materials and technologies are developed and tested in order to achieve maximum quality.

IXIL surgió en el mercado en 1.955 a través de una Empresa familiar en el corazón de Barcelona.

La constancia y el tesón de dos generaciones, con la voluntad de ofrecer siempre la máxima garantía en nuestros productos, han sido fundamentales para obtener un reconocimiento mundial, un gran trabajo de equipo en la fabricación, comercialización y distribución de la marca permite la competitividad en el mercado Internacional.

Los últimos avances tecnológicos están presentes en todos nuestros procesos de producción para permitir superar las más estrictas normativas europeas.

El desarrollo de los productos, tiene como base el diseño asistido por ordenador(CAD) el cual permite una mayor rapidez y una alta precisión en las adaptaciones.

Todo el proceso de producción esta apoyado informáticamente, desde las máquinas de corte por láser hasta los robots de soldadura.

IXIL está presente en el mundo de la competición donde cuenta con la confianza de pilotos de elite mundial, luchando en la categoría reina de Moto GP; donde se desarrollan y experimentan nuevos materiales y tecnologías con el fin de ofrecer la máxima calidad.

IXIL fit son apparition sur le marché du silencieux en 1955. C'est une Entreprise familiale située au coeur de Barcelone.

C'est au travers de deux générations jeunes et dynamiques et une volonté constante d'obtenir toujours la meilleure qualité que la marque IXIL se réjouit aujourd'hui d'avoir une reconnaissance mondiale.

C'est grâce à un important travail d'équipe en matière de fabrication, de commercialisation et de distribution qu'IXIL est présent sur le plan international.

Les derniers progrès technologiques sont présents tout au long du processus de fabrication permettant de dépasser les normes européennes les plus strictes.

La (CAD) conception assistée par ordinateur assure une plus grande précision dans nos projets et une meilleure rapidité d'exécution.

Tous les processus de fabrication sont assistés par ordinateurs, depuis les machines de coupes au laser jusqu'aux robots de soudures.

IXIL est présent dans le monde de la compétition où il bénéficie de la confiance de pilotes d'élite mondiale, luttant dans la catégorie reine du Moto GP. C'est dans la compétition que de nouveaux matériaux et de nouvelles technologies sont mises au point et testées dans le but d'offrir une qualité optimum à nos clients.

Als ein im Zentrum von Barcelona angesiedelter Familienbetrieb nahm **IXIL** im Jahre 1955 seine Geschäftstätigkeit auf.

Die Beharrlichkeit und Ausdauer, mit der sich zwei Generationen einer maximalen Qualität der angebotenen Erzeugnisse verschrieben, war die Grundlage für unsere heutige weltweite Anerkennung. Und durch einen ungebrochenen Teamgeist bei Herstellung, Vermarktung und Vertrieb der Marke ist es uns möglich, uns mit durchschlagendem Erfolg im internationalen Wettbewerb zu behaupten.

Die letzten technischen Fortschritte haben ihren Niederschlag in all unseren Produktionsverfahren gefunden, so daß den strengsten europäischen Normen voll Rechnung getragen werden kann.

Die Entwicklung unserer Produkte erfolgt computergestützt anhand der modernsten CAD-Verfahren, wodurch Zeit gespart und maximale Präzision bei all den verschiedenen Anwendungsbereichen erzielt wird.

Der gesamte Produktionsprozeß wird EDV-mäßig überwacht-von den Laserschneidmaschinen bis hin zu den Schweißautomaten.

IXIL ist im internationalen Rennsport bekannt und geschätzt und genießt das Vertrauen der weltweit besten Fahrer in der Moto GP-Klasse. Hier werden auch neue Materialklassen und technische Alternativen geprüft, um so stets und jederzeit maximale Qualität bieten zu können.

IXIL 品牌由一个家族企业于1955年在西班牙巴塞罗那成立。50多年来,通过两代企业领导人不断的努力,坚持提供最好的摩托车改装产品,得了全世界的认可。

我们是欧洲最大的改装摩托车排气管生产商,适配的车型从50CC到1400CC达到了上千种款式。在工厂的支持配合下,品牌的商业化和发行使我们在国际市场上享有很大竞争力我们在生产过程中运用最新的技术,确保产品达到最高的欧洲标准。所有产品运用电脑的(CAD)设计完成;从激光切割到机器焊接等,所有的生产流程都由电脑辅助控制,保证每个零件的性能得到最大的体现。

IXIL满怀信心活跃在赛车场上,在以先进的新材料和技术达到最好品质的世界顶级MOTOGP比赛行列里,我们享受着骑士带来的自信和荣誉!





IXIL RACING

IXIL Exhausts esta presente en las carreras mas competitivas de todo el mundo desde 1955. Moto GP ha sido nuestro mayor laboratorio para ensayar nuestros productos, trabajando a codo con los equipos mas relevantes. Desde WSBK hasta CSBK, Z CUP, WSSP300, CBR300CUP, NINJA 250CUP, NK250CUP y muchas otras competiciones de primer nivel, están apoyadas por IXIL Exhausts. Toda esta tecnología y experiencia en la competición, certifican todos nuestros productos.

IXIL Exhausts is present in the most competitive races around the world since 1955. Moto GP had been our biggest laboratory for test our products, working side by side with the most important teams. From WSBK to CSBK, Z CUP, WSSP300, CBR300CUP, NINJA250CUP, NK250CUP and many other competitions are powered by IXIL Exhausts. All this technology and experience on competition, certify all our products.

IXIL Exhausts est présent dans les courses les plus compétitives du monde entier depuis 1955. Moto GP a été notre plus grand laboratoire pour tester nos produits, travaillant aux côtés des plus grandes équipes. De la WSBK à la CSBK, en passant par la Z CUP, la WSSP300, la CBR300CUP, la NINJA250CUP, la NK250CUP et bien d'autres compétitions sont équipés par IXIL Exhausts. Toute cette technologie et cette expérience sur la compétition, certifient tous nos produits.

IXIL Exhausts ist seit 1955 in allen relevanten Motorradrennserien der Welt zu finden. Von WSBK zu CSBK, Z CUP, WSSP300, CBR300CUP, NINJA250CUP, NK250CUP und viele andere Rennserien sind powered by IXIL Exhausts. Alle Erfahrungen die dort erlangt wurden fließen in alle IXIL Produkte und werden so ständig weiter entwickelt.

自1955年以来, IXIL 排气管一直出现在世界上竞争最激烈的赛事中。摩托GP是测试我们产品最大的实验室,作为供应商,我们与最具影响力的车队并肩作战。从WSBK到CSBK, Z CUP, WSSP300, CBR300CUP, NINJA250CUP, NK250CUP 及许多其他一级赛事,均由IXIL Exhausts提供支持。这些在赛事中不断积累的技术和经验是我们所有产品的质量保证。



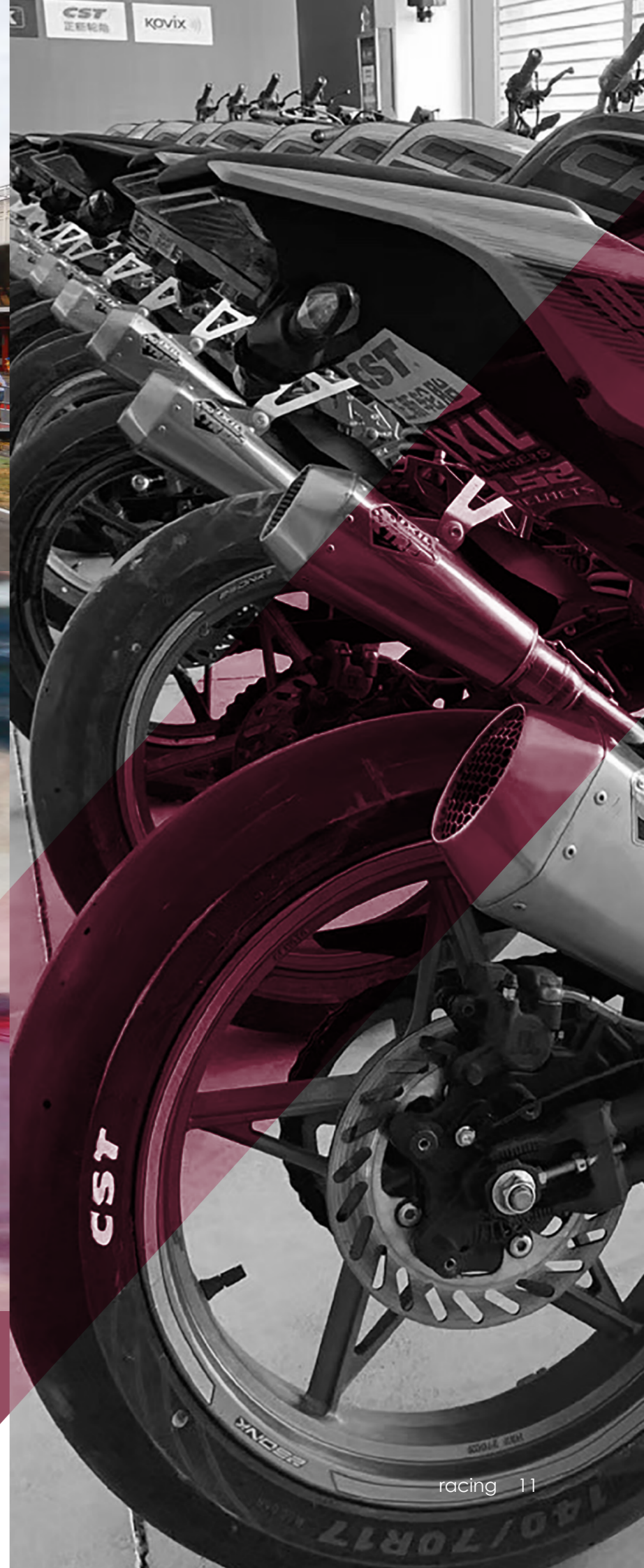



IXIL TUNING

La extensa gama de productos **IXIL** con diseños innovadores, siempre han contado con la confianza de grandes preparadores de motocicletas. El diseño vanguardista de nuestros productos, hace perfecto el equilibrio entre la belleza y la potencia.

The large range of **IXIL** products with innovative designs, always had the confidence of the best custom bikes professionals. The advanced design of our products, makes perfect the balance between beauty and power.

La grande gamme de produits **IXIL** avec des designs innovants, a toujours eu la confiance des meilleurs professionnels de la customisation. Le design avancé de nos produits, rend parfait l'équilibre entre la beauté et la performance.

Die große Vielfalt der **IXIL** Produkte mit ihrem innovativem Design genießt das Vertrauen vieler Customizer der Motorradszene. Das fortschrittliche Design unserer Produkte vereint die Balance zwischen Schönheit und optimaler Leistung.

我们产品的前卫设计使美观与力量之间达到完美平衡。**IXIL** 的产品种类多样，设计新颖，是摩托车专业涂装修理的放心之选。我们产品的前卫设计是美观与力量的完美平衡。



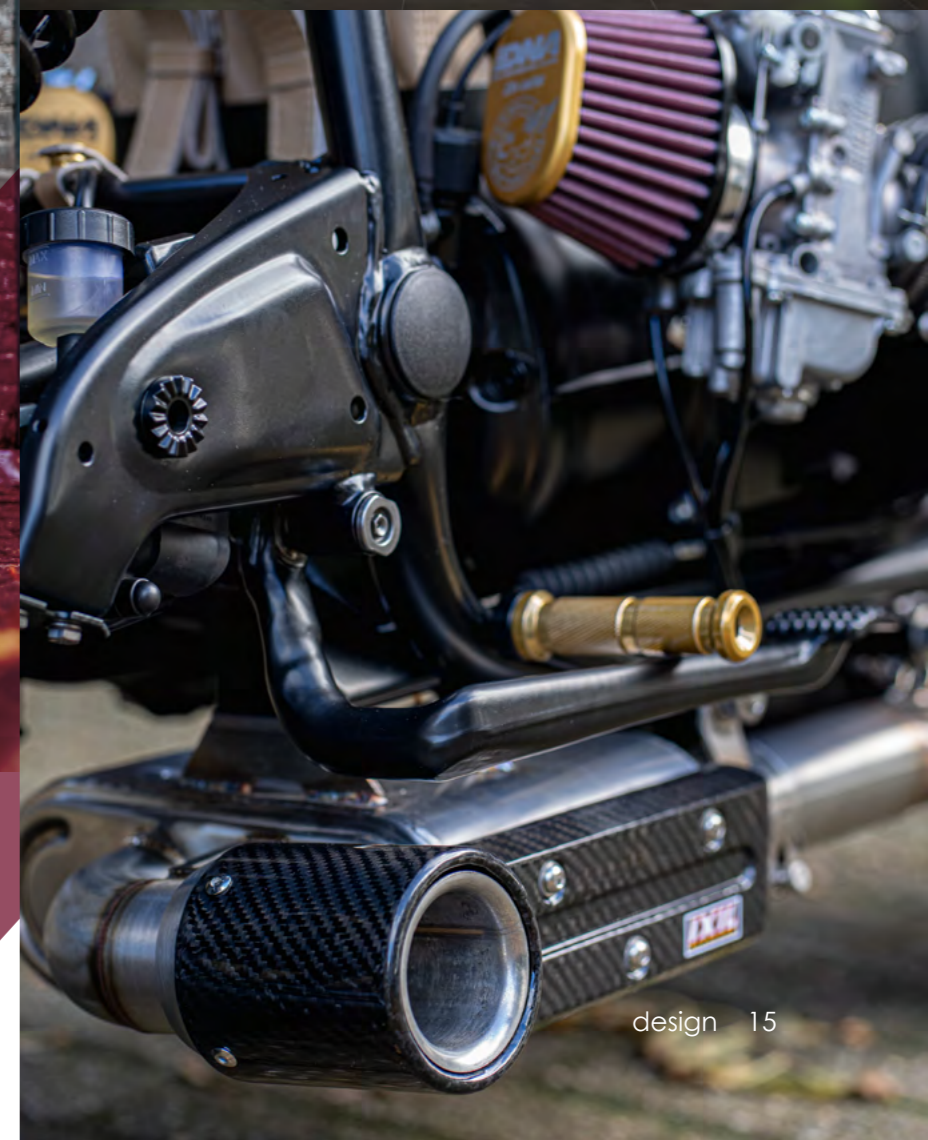

IXIL
exhaust



RB - Exhaust Line

Race Xtrem Black



TECHNICAL DATA

Silenciador fabricado en acero inoxidable AISI 304 con acabado lacado negro. Tapa salida BIG FLOW fabricada en acero inoxidable AISI 304 con acabado lacado negro.

Silencer made on stainless Steel AISI 304 with black lacquer finish.
End cap "BIG FLOW" made on stainless Steel AISI 304 with black lacquer finish.

Schalldämpfer aus Edelstahl AISI 304 mit Schwarz lackiert.
Abdeckung des Ausganges GROSSER FLUSS im Edelstahl AISI 304 mit Schwarz lackiert.

Silencieux laqué noir fabriqué en acier inoxydable AISI 304 laque noir. La sortie de gaz BIG FLOW fabriqué en acier inoxydable AISI 304 laque noir.

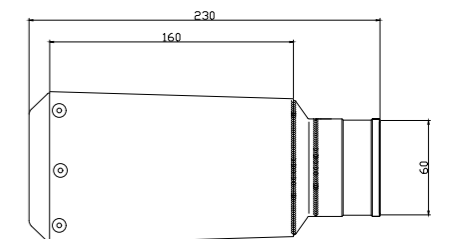
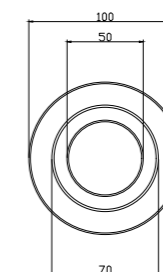

RC - Exhaust Line
Race Xtrem



TECHNICAL DATA

Silenciador fabricado en acero inoxidable AISI 304 en acabado satinado TITANIUM Look. Tapa de salida cónica fabricada en fibra de carbono resinada en epoxi de alta temperatura con acabado brillante.

Silencer made on stainless Steel AISI 304 with satin TITANIUM look finish. Conical end cap manufactured from carbon fiber epoxi resin with bright finish.

Silencieux fabrique en acier inoxydable AISI 304 finition satiné TITANIUM Look. Sortie de gaz conique fabrique a partir de résine époxy de fibre de carbone a haute température avec une finition brillante.

Der Schalldämpfer, der im Edelstahl hergestellt wurde, beendete AISI 304 im satinierten TITANIUM Look. Konische hitzebeständige carbon endkappe in glänzendem finish.

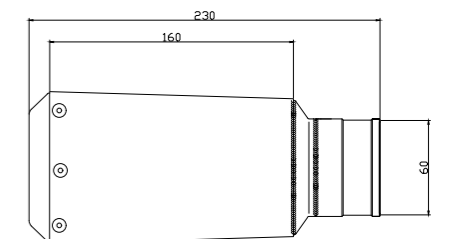
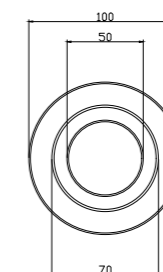

RC3B - Exhaust Line
Round Black Xtrem



TECHNICAL DATA

Silenciador fabricado en acero inoxidable AISI 304 con acabado lacado negro. Tapa salida BIG FLOW fabricada en acero inoxidable AISI 304 con acabado satinado.

Silencer made on stainless Steel AISI 304 with black lacquer finish. End cap "BIG FLOW" made on stainless Steel AISI 304 with satin finish.

Schalldämpfer aus Edelstahl AISI 304 mit Schwarz lackiert. Abdeckung des Ausganges GROSSER FLUSS im Edelstahl AISI 304 mit satingehilfen.

Silencieux laqué noir fabriqué en acier inoxydable AISI 304 laque noir. La sortie de gaz BIG FLOW fabriqué en acier inoxydable AISI 304 satiné.

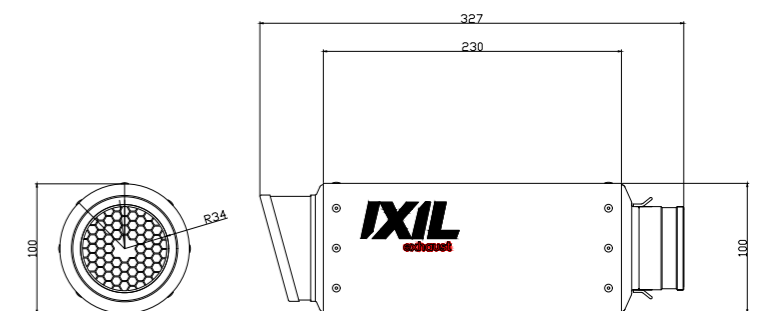

XC - Exhaust Line

Carbon Xtrem



TECHNICAL DATA

Silenciador fabricado en fibra de carbono resinado en epoxy de alta temperatura con acabado negro brillante. Tapa de salida fabricada también en fibra de carbono de alta temperatura con acabado negro brillante.

Silencer manufactured from high temperature carbon fiber epoxy resin with bright polished finish. End cap manufactured from high temperature carbon fiber epoxy resin with bright polished finish.

Silencieux fabriqué avec carbone haute température. La sortie de gaz également fabriqués en carbone haute température.

Auspuff hergestellt aus hitzebeständige Carbon. Konische, hitzebeständige Carbon Endkappe in glänzendem finish.

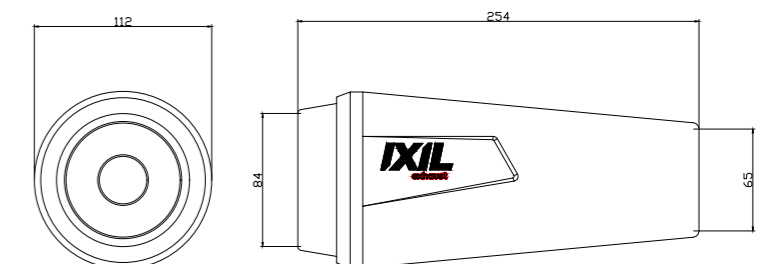

SX1 - Exhaust Line

Super Xtreme



TECHNICAL DATA

Silenciador fabricado en acero inoxidable AISI 304 en acabado satinado mate. Tapa de salida y protector fabricado en fibra de carbono resinado en epoxy de alta temperatura con acabado negro brillante.

Silencer manufactured from AISI304 stainless steel with a satin polished finish. End cap and protector manufactured from high temperature carbon fiber epoxy resin with bright polished finish.

Silencieux fabriqué en acier inoxydable AISI304 et soudures TIG.

La sortie de gaz et le protecteur thermique sont fabriqués en carbone haute température.

Ein aus rostfreiem AISI304 stahl hergestellter schalldämpfer mit einer seidenmatt polierten oberfläche.

Sowohl die endkappe als auch teile des schalldämpfers zeichnen sich durch einen aus edlem carbon gefertigten hitzeschutz aus.

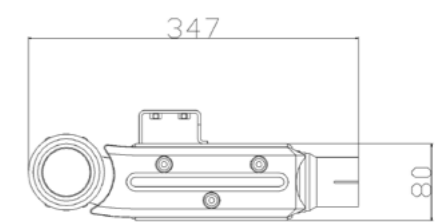
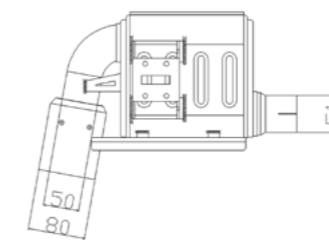

MXT - Exhaust Line
Mega Xtrem



TECHNICAL DATA

Silenciador fabricado en acero inoxidable AISI 304 con acabado satinado mate. Tapa de salida asimétrica fabricada en aluminio inyectado con acabado lacado negro.

Silencer manufactured from AISI 304 stainless Steel with a satin polished finish. Asymmetric and conical end cap, manufactured in aluminium with high temperature black lacquer.

Silencieux fabrique en acier inoxydable AISI 304 avec finition satine mate. Sans entretien et sonorite amitreee. Sortie de gaz conique et asymetrique fabrique en aluminium injecte laque noir.

Ein aus rostfreiem AISI 304 stahl hergestellter Schalldampfer mit einer seidenmatt polierten Oberfläche. Die aus aluminium gefertigte asymmetrische und konische endkappe wurde mit einer hitzebeständigen, Scharzen lackierung vollendet.

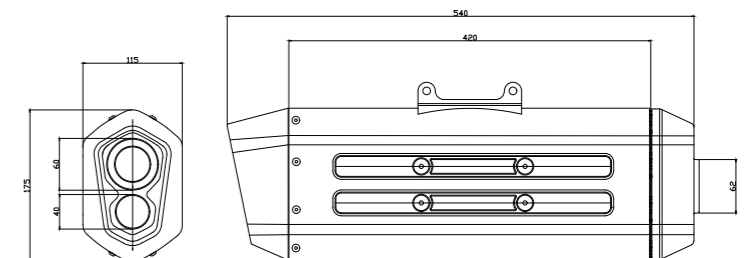

MXR - Exhaust Line
Mega Xtrem



TECHNICAL DATA

Silenciador fabricado en acero inoxidable AISI 304 con acabado satinado mate. Tapa de salida Conica AISI 304 satinada.

Silencer manufactured from AISI 304 stainless Steel with a satin polished finish. Conic end cap from AISI 304 with satin finish.

Silencieux fabrique en acier inoxydable AISI 304 avec finition satine mate. Sans entretien et sonorite amitreee. Sortie de gaz conic AISI 304 avec finition satiné.

Ein aus rostfreiem AISI 304 stahl hergestellter Schalldampfer mit einer seidenmatt polierten Oberfläche. Abdeckung des Ausganges GROSSER FLUSS im Edelstahl AISI 304 mit satingehilfen.

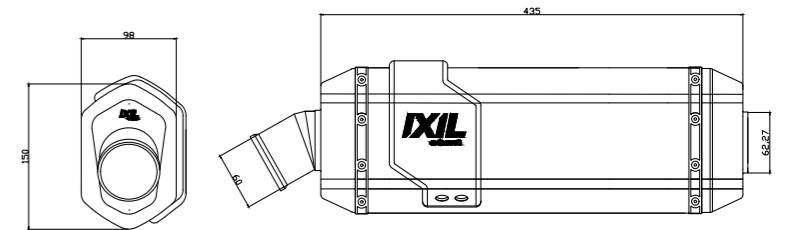

RALLY - Exhaust Line

Mega Xtrem



TECHNICAL DATA

Silenciador fabricado en acero inoxidable AISI 304 con acabado satinado mate. Tapa de salida Conica AISI 304 satinada.

Silencer manufactured from AISI 304 stainless Steel with a satin polished finish. Conic end cap from AISI 304 with satin finish.

Silencieux fabrique en acier inoxydable AISI 304 avec finition satine mate. Sans entretien et sonorite amitresee. Sortie de gaz conic AISI 304 avec finition satiné.

Ein aus rostfreiem AISI 304 stahl hergestellter Schalldampfer mit einer seidenmatt polierten Oberfläche. Abdeckung des Ausganges GROSSER FLUSS im Edelstahl AISI 304 mit satingehilfen.

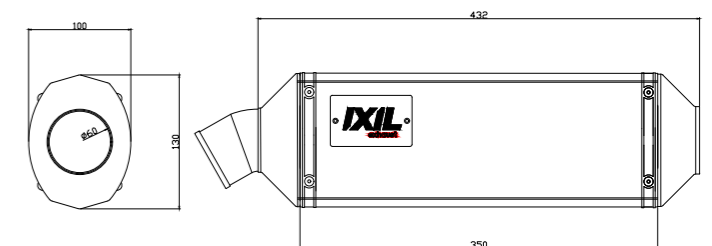

L5X - Exhaust Line

Dual Hyperlow XXL



TECHNICAL DATA

Silenciador fabricado en acero inoxidable AISI 304 con acabado satinado mate. Tapa salida fabricada en acero inoxidable AISI 304 en acabado satinado mate.

Silencer manufactured from AISI304 stainless steel with a satin polished finish. End caps made from AISI304 stainless steel with a satin polished finish.

Silencieux fabriqué en acier inoxydable AISI 304 avec finition satiné mate. Sorties de gaz en acier inoxydable AISI 304 avec finition satiné mate.

Ein aus rostfreiem AISI304 stahl hergestellter schalldämpfer mit einer seidenmatt polierten oberfläche.

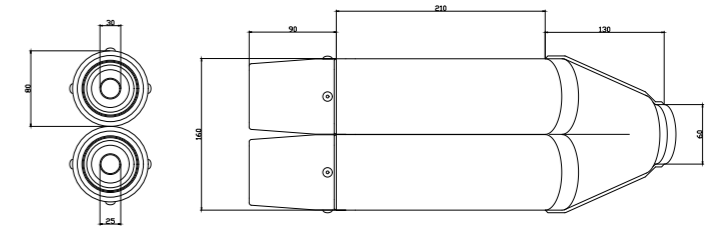

L3XB - Exhaust Line

Dual Hyperlow Black XL



TECHNICAL DATA

Silenciador fabricado en acero inoxidable AISI 304 con acabado lacado negro. Tapa salida fabricada en aluminio CNC anodizado mate.

Silencer manufactured from AISI 304 stainless steel with black lacquer finish. End caps made in aluminum with matt anodizing finish.

Silencieux fabriqué en acier inoxydable AISI 304 avec finition laqué noire. Sorties de gaz en aluminium CNC anodisé gris.

Ein aus rostfreiem AISI304 stahl hergestellter schalldämpfer mit einer schwarzen lackierung. Die aus aluminium gefertigten endkappen zeichnen sich durch eine matte eloxierte oberfläche aus.

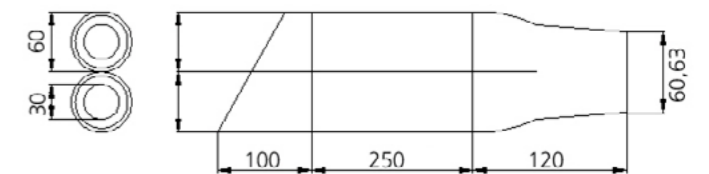

L2X - Exhaust Line

Dual Hyperlow



TECHNICAL DATA

Silenciador fabricado en acero inoxidable AISI304 con acabado satinado mate. Tapa de salida fabricada en aluminio anodizado brillante.

Silencer manufactured from AISI304 stainless steel with a satin polished finish. End caps made in aluminum with bright anodizing finish.

Silencieux fabriqué en acier inoxydable AISI304 avec finition satiné mate. Sorties de gaz en aluminium anodisé brillant.

Ein aus rostfreiem AISI304 stahl hergestellter schalldämpfer mit einer seidenmatt polierten oberfläche. Die aus aluminium gefertigten endkappen zeichnen sich durch eine glänzende eloxierte oberfläche aus.

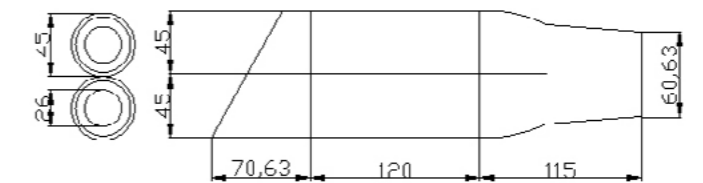

SOVE - Exhaust Line

Hexoval Xtreme Evolution



TECHNICAL DATA

Silenciador fabricado en acero inoxidable AISI304 con acabado satinado mate. Tapa de salida cónica asimétrica fabricada en aluminio inyectado con acabado lacado negro.

Silencer manufactured from AISI304 stainless steel with a satin polished finish. Asymmetric and conical end cap, manufactured in aluminum with high temperature black lacquer.

Silencieux fabriqué en acier inoxydable AISI304 avec finition satiné mate. Sans entretien et sonorité maîtrisée. Sortie de gaz conique et asymétrique fabriqué en aluminium injecté laqué noir.

Ein aus rostfreiem AISI304 stahl hergestellter Schalldämpfer mit einer seidenmatt polierten Oberfläche.

Die aus aluminium gefertigte asymmetrische und konische endkappe wurde mit einer hitzebeständigen schwarzen lackierung vollendet.

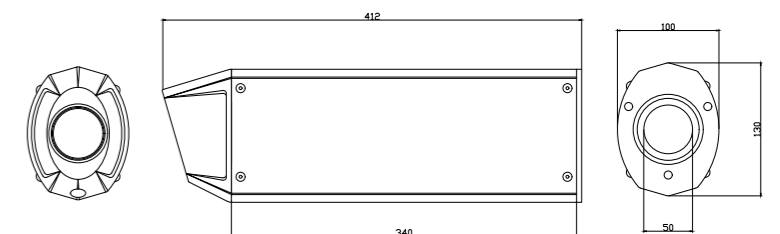

V4S - Exhaust Line

Hexoval Xtreme Evolution



TECHNICAL DATA

Silenciador fabricado en acero inoxidable AISI304 con acabado satinado mate. Tapa de salida cónica asimétrica fabricada en aluminio inyectado con acabado lacado negro.

Silencer manufactured from AISI304 stainless steel with a satin polished finish. Asymmetric and conical end cap, manufactured in aluminum with high temperature black lacquer.

Silencieux fabriqué en acier inoxydable AISI304 avec finition satiné mate. Sans entretien et sonorité maîtrisée. Sortie de gaz conique et asymétrique fabriqué en aluminium injecté laqué noir.

Ein aus rostfreiem AISI304 stahl hergestellter Schalldämpfer mit einer seidenmatt polierten Oberfläche. Die aus aluminium gefertigte asymmetrische und konische endkappe wurde mit einer hitzebeständigen schwarzen lackierung vollendet.

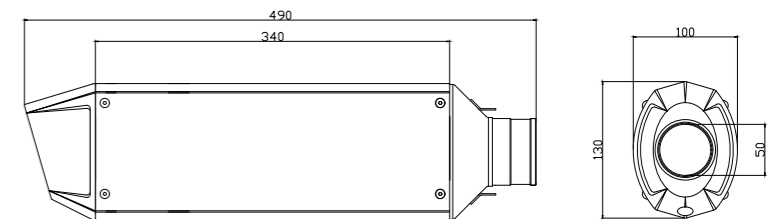

V4B - Exhaust Line

Hexoval Xtreme Evolution



TECHNICAL DATA

Silenciador fabricado en acero inoxidable AISI 304 con acabado lacado negro. Tapa de salida cónica asimétrica fabricada en fibra de carbono resinada en epoxi de alta temperatura con acabado brillante.

Silencer made on stainless Steel AISI 304 with black lacquer finish. Asymmetric and conical end cap manufactured from high temperature carbon fiber epoxy resin with bright finish.

Silencieux laqué noir fabriqué en acier inoxydable AISI 304 laque noir. Embout asymétrique et conique fabriqué à partir de résine époxy de fibre de carbone à haute température avec une finition brillante.

Schalldämpfer aus Edelstahl AISI 304 mit Schwarz lackiert. Asymetrische und konische, hitzebeständige Carbon Endkappe in glänzendem finish.

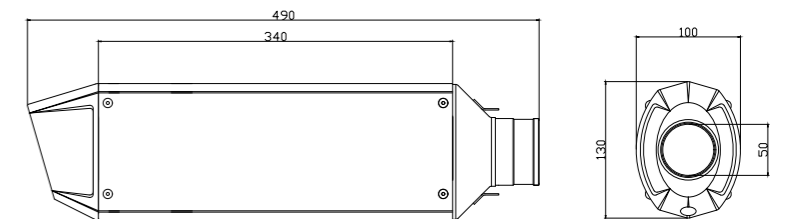

VTR - Exhaust Line

Titanium Race



TECHNICAL DATA

Silenciador fabricado en TITANIO. Tapa de salida cónica asimétrica fabricada en fibra de carbono resinada en epoxi de alta temperatura con acabado brillante.

Silencer manufactured from TITANIUM. Asymmetric and conical end cap manufactured from high temperature carbon fiber epoxy resin with bright finish.

Silencieux fabriqué en TITANE. Embout asymétrique et conique fabriqué à partir de résine époxy de fibre de carbone à haute température avec une finition brillante.

Auspuff hergestellt aus TITAN. Asymetrische und konische, hitzebeständige Carbon Endkappe in glänzendem finish.

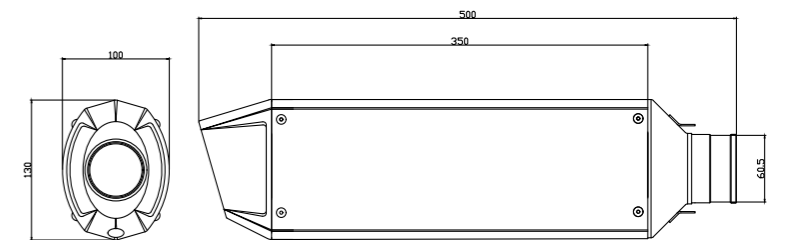

IRONHEAD

by **IXIL**



HC2 - Ironhead Line



TECHNICAL DATA

Silenciador fabricado en acero inoxidable AISI 304 con acabado cromado y logotipo marcado con Laser.

Tapa de salida adaptable en 4 posiciones, fabricada en acero inoxidable AISI 304 con acabado cromado.

Silencer manufactured from AISI 304 stainless Steel with chrome finish and Laser print Logo.

Exit cover adjustable in 4 positions, manufactured from AISI 304 stainless Steel with chrome finish.

Silencieux fabrique en acier inoxydable AISI 304 avec une finition chrome et un marquage du logo a Laser.
Sortie réglables en quatre positions fabrique en acier inoxydable AISI 304 avec une finition chrome.

Schalldampfer aus Edelstahl AISI 304 mit Chrom und Laser logo.

Umfassen sie den Ausgang in vier positionen verstellbar aus Edelstahl AISI 304 mit Chrom.



HC2B - Ironhead Line



TECHNICAL DATA

Silenciador fabricado en acero inoxidable AISI 304 con acabado lacado negro y logotipo marcado con Laser.

Tapa de salida adaptable en 4 posiciones, fabricada en acero inoxidable AISI 304 con acabado lacado negro.

Silencer manufactured from AISI 304 stainless Steel with black lacquer finish and Laser print Logo.
Exit cover adjustable in 4 positions, manufactured from AISI 304 stainless Steel with black lacquer finish.

Silencieux fabrique en acier inoxydable AISI 304 avec une finition laquee noire et un marquage du logo a Laser.
Sortie réglables en quatre posotions fabrique en acier inoxydable AISI 304 avec une finition laquee noire.

Schalldampfer aus Edelstahl AISI 304 mit Schwarz lackiert und Laser logo.
Umfassen sie den Ausgang in vier positionen verstellbar aus Edelstahl AISI 304 mit Schwarz lackiert.

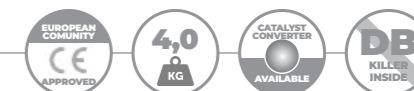

HC1 - Ironhead Line



TECHNICAL DATA

Silenciador fabricado en acero inoxidable AISI 304 con acabado cromado y logotipo marcado con Laser.

Tapa de salida adaptable en 4 posiciones, fabricada en acero inoxidable AISI 304 con acabado cromado.

Silencer manufactured from AISI 304 stainless Steel with chrome finish and Laser print Logo.

Exit cover adjustable in 4 positions, manufactured from AISI 304 stainless Steel with chrome finish.

Silencieux fabrique en acier inoxydable AISI 304 avec une finition chrome et un marquage du logo a Laser. Sortie réglables en quatre positions fabrique en acier inoxydable AISI 304 avec une finition chrome.

Schalldampfer aus Edelstahl AISI 304 mit Chrom und Laser logo.

Umfassen sie den Ausgang in vier positionen verstellbar aus Edelstahl AISI 304 mit Chrom.



HC1B - Ironhead Line



TECHNICAL DATA

Silenciador fabricado en acero inoxidable AISI 304 con acabado lacado negro y logotipo marcado con Laser.
Tapa de salida adaptable en 4 posiciones, fabricada en acero inoxidable AISI 304 con acabado lacado negro.

Silencer manufactured from AISI 304 stainless Steel with black lacquer finish and Laser print Logo.
Exit cover adjustable in 4 positions, manufactured from AISI 304 stainless Steel with black lacquer finish.

Silencieux fabrique en acier inoxydable AISI 304 avec une finition laquee noire et un marquage du logo a Laser.
Sortie réglables en quatre posotions fabrique en acier inoxydable AISI 304 avec une finition laquee noire.

Schalldampfer aus Edelstahl AISI 304 mit Schwarz lackiert und Laser logo.
Umfassen sie den Ausgang in vier positionen verstellbar aus Edelstahl AISI 304 mit Schwarz lackiert.



OVC11 - Ironhead Line



TECHNICAL DATA

Silenciador fabricado en acero inoxidable AISI 304 con acabado pulido y logotipo marcado con Laser. Tapa de salida fabricada en acero inoxidable AISI 304 con acabado pulido.

Silencer manufactured from AISI 304 stainless Steel polished and Laser print Logo. Exit cap manufactured from AISI 304 stainless Steel polished.

Silencieux fabrique en acier inoxydable AISI 304 avec une finition satinée et un marquage du logo a Laser. Sortie fabrique en acier inoxydable AISI 304 avec une finition satinée.

Schalldampfer aus Edelstahl AISI 304 geburstet und Laser logo. Ausgang aus Edelstahl AISI 304 geburstet.



OVC13 - Ironhead Line



TECHNICAL DATA

Silenciador fabricado en acero inoxidable AISI 304 con acabado pulido y logotipo marcado con Laser. Tapa de salida fabricada en acero inoxidable AISI 304 con acabado pulido.

Silencer manufactured from AISI 304 stainless Steel polished and Laser print Logo. Exit cap manufactured from AISI 304 stainless Steel polished.

Silencieux fabrique en acier inoxydable AISI 304 avec une finition satinée et un marquage du logo a Laser. Sortie fabrique en acier inoxydable AISI 304 avec une finition satinée.

Schalldampfer aus Edelstahl AISI 304 geburstet und Laser logo. Ausgang aus Edelstahl AISI 304 geburstet.





IXIL France

La Roche de Chaléas
42660 Saint Régis du Coin

TEL. 04 77 343 311 / 04 77 518 337

P: 06 845 670 12

FAX 04 77 210 492

COMMANDES: isabelle@ixilfrance.fr

SAV: denis@ixilfrance.fr

COMPTABILITE: compta@ixilfrance.fr



IXIL head office

P.I. CAN CUIÀS · ARQUITECTURA, 2
08110 - MONTCADA I REIXAC
BARCELONA · ESPAÑA

 34-93 565 06 60
 34-93 565 06 61
 ixil@ixil.com
 www.ixil.com